



## MSW2T-0025-195

### SP2T Surface Mount High Power Series PIN Diode Switch

#### Features:

- Surface Mount SP2T Switch: 5mm x 8mm x 2.5mm
- Industry Leading Average Power Handling: 160W CW
- L Band Frequency Range: 1 GHz to 2 GHz
- Support High RF Peak Power: Handling: 500W
- Low Insertion Loss: < 0.4 dB
- High IP3: >65 dBm
- Operates for Positive Voltage Only: (+5V & +28V to +200V)
- RoHS Compliant

#### Description:

The MSW2T-0025-195 surface mount High Power PIN Diode switch leverages high reliability hybrid manufacturing processes which yield proven superior performance to both MMIC and Glass Carrier based technologies. The hybrid design approach permits precise PIN Diode selection to optimize RF performance while maintaining competitive cost targets. The MSW2T-0025-195 is an asymmetrical SP2T which was designed to maximize the Tx-Rx Isolation while minimizing the Tx-ANT loss. The MSW2T-0025-195 can safely handle L Band CW powers of up to 50 dBm and peak power levels up to 57 dBm while being operated at an ambient temperature of +85°C. The small form factor (8mm x 5mm x 2.5mm) offers world class power handling, low insertion loss, and superior intermodulation performance exceeding all competitive technologies.

#### Typical Applications:

- Radar T/R Modules
- Switch Bank Filters
- Mil-Com Radios

The MSW2T-0025-195 series of High Power SP2T switches are intended for use in high power, high reliability, mission critical applications across the 1 GHz to 2.0 GHz Band frequency ranges. The manufacturing process has been proven through years of extensive use in high reliability applications.

The MSW2T-0025-195 SP2T switches are fully RoHS compliant.

**ESD and Moisture Sensitivity Level Rating:**

The MSW2T-0025-195 carries an ESD rating of Class 1C, Human Body Model (HBM) and a moisture sensitivity rating of MSL 1.

**MSW2T-0025-195 Specifications @  $Z_0 = 50\Omega$ ;  $T_a = +25^\circ\text{C}$** 

Parameter	Symbol	Unit	Test Conditions	Min Value	Typical Value	Max Value
Frequency	F	GHz		1.0		2.0
Tx-Ant IL	IL	dB	0 V @ 200 mA (Tx) +28V @ 0 mA (Rx)		0.3	0.4
Ant-Rx IL	IL	dB	0 V @ 100 mA (Rx) +28V @ 0 mA (Tx)		0.3	0.4
Tx-Ant RL	RL(Tx)	dB	0 V @ 200 mA (Tx) +28V @ 0 mA (Rx)	18	20	
Ant-Rx RL	RL(Rx)	dB	0 V @ 100 mA (Rx) +28V @ 0 mA (Tx)	18	20	
Tx-Rx Isolation	ISO(Rx)	dB	0 V @ 200 mA (Tx) +28V @ 0 mA (Rx)	15	20	
Rx-Tx Isolation	ISO(Tx)	dB	0 V @ 100 mA (Rx) +28V @ 0 mA (Tx)	13	15	
CW Incident Power, Ant-Tx Low Loss State (Note 2)	$P_{inc}(CW)$	dBm	0 V @ 200 mA (Tx) +28V @ 0 mA (Rx) 1.5:1 source & load VSWR		50	
CW Incident Power, Ant-Rx Low Loss State (Note 2)	$P_{inc}(CW)$	dBm	0 V @ 100 mA (Rx) +28V @ 0 mA (Tx) 1.5:1 source & load VSWR		40	
Peak Incident Power Ant-Tx Low Loss State	$P_{inc}(PK)$	dBm	0 V @ 200 mA (Tx) +28V @ 0 mA (Rx) 1.5:1 source & load VSWR, 10us PW, 1% DC		57	
Switching Speed	$T_{sw}$	usec	10% to 90% RF voltage		1.5	2.0
Input 3 <sup>rd</sup> Order Intercept Point	IIP3		F1=1 GHz, F2=1.01GHz P1=P2=0 dBm	60	65	

Notes:

- 1) Switching speed (50% TTL – 10% to 90% RF Voltage) is a function of the driver circuit. An RC current spike network is employed on the driver output to provide the transient current spike to remove the I region stored charge. Typical values are: R = 50 to 220Ω and C = 470 to 1,000 pF.
- 2) The minimum DC reverse bias voltage to maintain high resistance in the OFF state is determined by the RF frequency, incident power and VSWR. The minimum DC reverse voltage values are provided in the Minimum Reverse Voltage Table below.

**MSW2T-0025-195 SP2T Schematic**

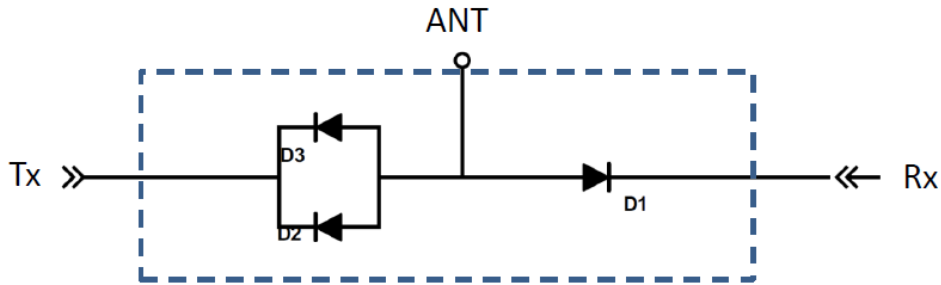

**MSW2T-0025-195 Driver Interface Schematic and Associated Truth Table**

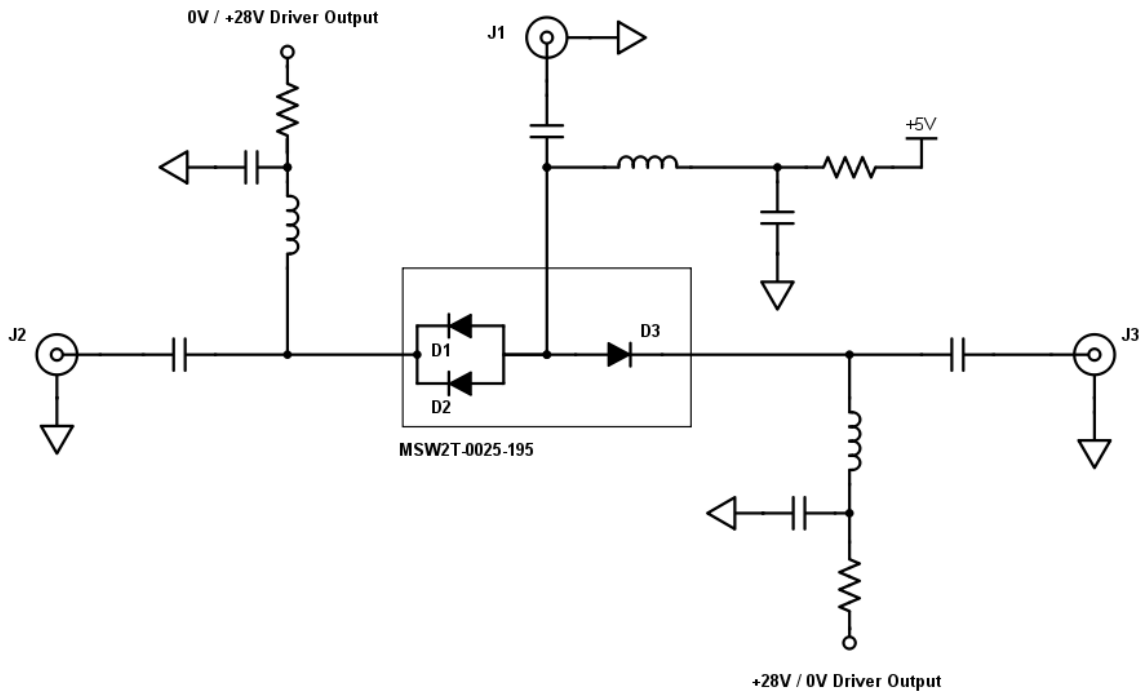

## RF Biasing Network Values

Part	F (GHz)	DC Blocking Caps	Inductors	RF Bypass Caps
		<b>C3, C4</b>	<b>L1, L2, L3</b>	<b>C1, C2, C5</b>
MSW2T-0025-195	1.0 – 2.0	27 pF	82 nH	270 Pf

R1, R2 and R3 = Bias Current Setting Resistors. Recommend min 100mA to forward bias loss insertion loss path; min 30mA for high isolation.

## RF Truth Table

Tx-Ant Path	Rx-ANT Path	ANT Bias	Tx Bias	Rx Bias
Low Loss	Isolation	5V @ 200mA	0V @ 200 mA	28V @ 0mA
Isolation State	Low Loss	5V @ 100mA @	28V @ 0m,A	0V @ 100mA

## Minimum Reverse Bias Voltage @ J1, J2 Ports vs Freq for 100W CW Operations

Part	1 GHz	2 Ghz
MSW2T-0025-195	120 V	80V

Notes:

- 1) Signal conditions: Input Power: 100W CW

## MSW2T-0025-195 Absolute Maximum Ratings @ $T_A = +25^\circ\text{C}$ (unless otherwise denoted)

Parameter	Absolute Maximum Value
Forward Current @ Tx or Rx	300mA
Reverse Voltage @ Tx or Rx	250V
Reverse Voltage @ DC	250V
Forward Diode Voltage	1.2 V @ 250 mA
Operating Temperature	-65 °C to +125 °C
Storage Temperature	-65 °C to +150 °C
Junction Temperature	+175 °C
Assembly Temperature	+260 °C for 10 seconds
CW Incident Power Handling Source & Load VSWR = 1.5 : 1 (Cold Switching) $T_{CASE} = 85^\circ\text{C}$	+52 dBm @ +85 °C Case Temp
Peak Incident Power Handling Source & Load VSWR = 1.5 : 1 (Cold Switching) $T_{CASE} = 85^\circ\text{C}$	+57 dBm @ 10 usec pulse, 1% duty cycle @ +85 °C Case Temp
Total Dissipated RF & DC Power (Cold Switching) $T_{CASE} = 85^\circ\text{C}$	4W @ +85 °C Case Temp

Notes:.

- 1) Backside RF and DC grounding area of the MSW2T-0025-195 must be completely solder attached to the RF Circuit board for proper electrical and thermal circuit grounding.

**Assembly Instructions**

The MSW2T-0025-195 High Power Switch are available in either tube or Tape & Reel format. The MSW2T-0025-195 may be attached to the printed circuit card using solder reflow procedures using either RoHS or Sn63/Pb37 type solders per the Table and Temperature Profile Graph shown below:

Profile Parameter	Sn-Pb Assembly Technique	RoHS Assembly Technique
Average ramp-up rate ( $T_L$ to $T_P$ )	3°C/sec (max)	3°C/sec (max)
Preheat		
Temp Min ( $T_{smin}$ )	100°C	100°C
Temp Max ( $T_{smax}$ )	150°C	150°C
Time (min to max) ( $t_s$ )	60 – 120 sec	60 – 120 sec
$T_{smax}$ to $T_L$		
Ramp up Rate		3°C/sec (max)
Peak Temp ( $T_P$ )	225°C +0°C / -5°C	260°C +0°C / -5°C
Time within 5°C of Actual Peak Temp ( $T_P$ )	10 to 30 sec	20 to 40 sec
Time Maintained Above:		
Temp ( $T_L$ )	183°C	217°C
Time ( $t_L$ )	60 to 150 sec	60 to 150 sec
Ramp Down Rate	6°C/sec (max)	6°C/sec (max)
Time 25°C to $T_P$	6 minutes (max)	8 minutes (max)

**Solder Re-Flow Time-Temperature Profile**

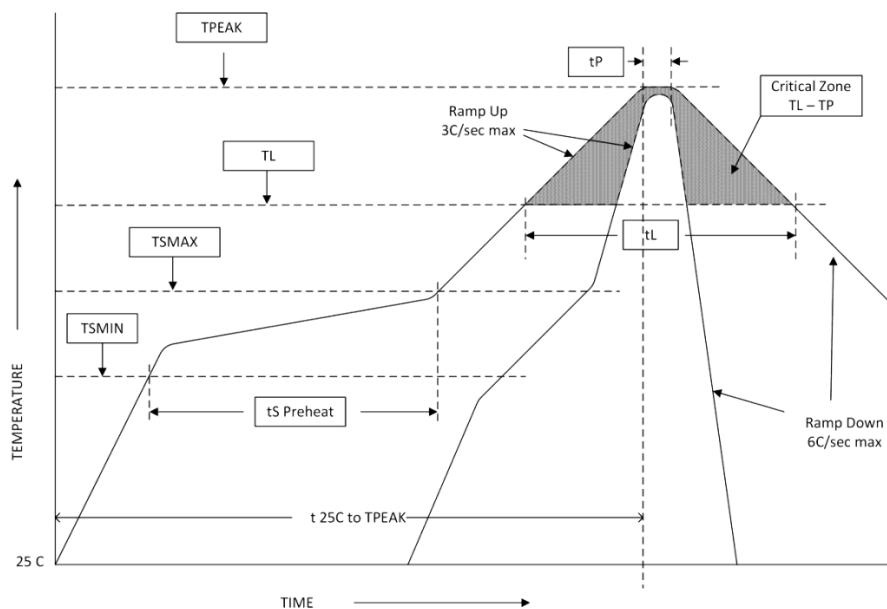

# MSW2T-0025-195 SP2T Package Outline Drawing

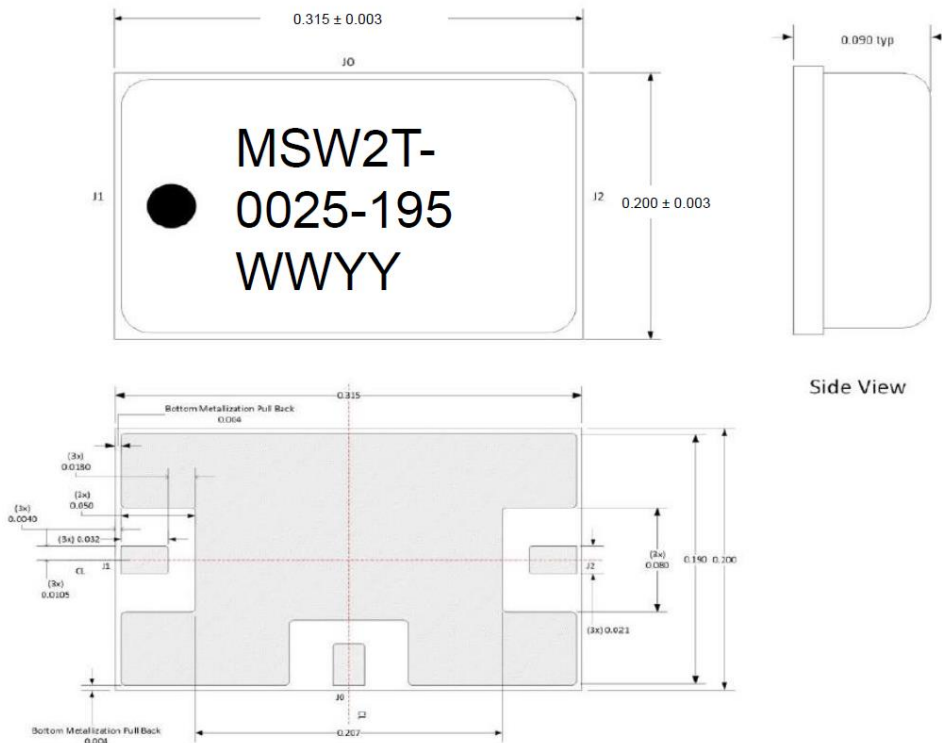

**Note:**

- 1) Metalized area on backside is the RF, DC and Thermal ground. In user's end application this surface temperature must be managed to meet the power handling requirements.
- 2) All dimensions in inches.

## Thermal Design Considerations

The design of the MWT-2061-195 High Power Switches permits the maximum efficiency in thermal management of the PIN Diodes while maintaining extremely high reliability. Optimum switch performance and reliability of the switch can be achieved by the maintaining the base ground surface temperature of less than 85°C.

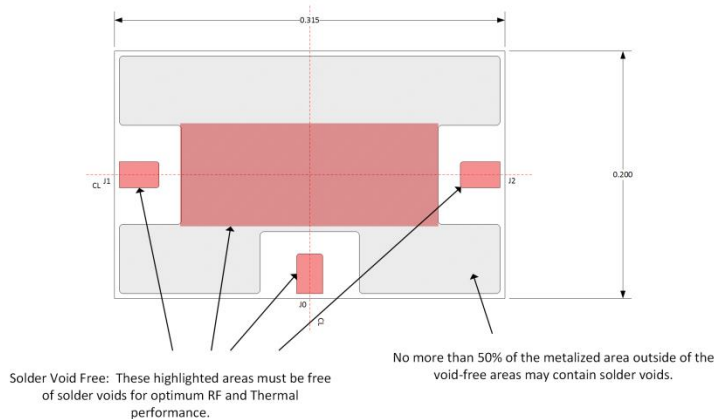

### Recommended RF Circuit Solder Footprint for the MSW2T-0025-195

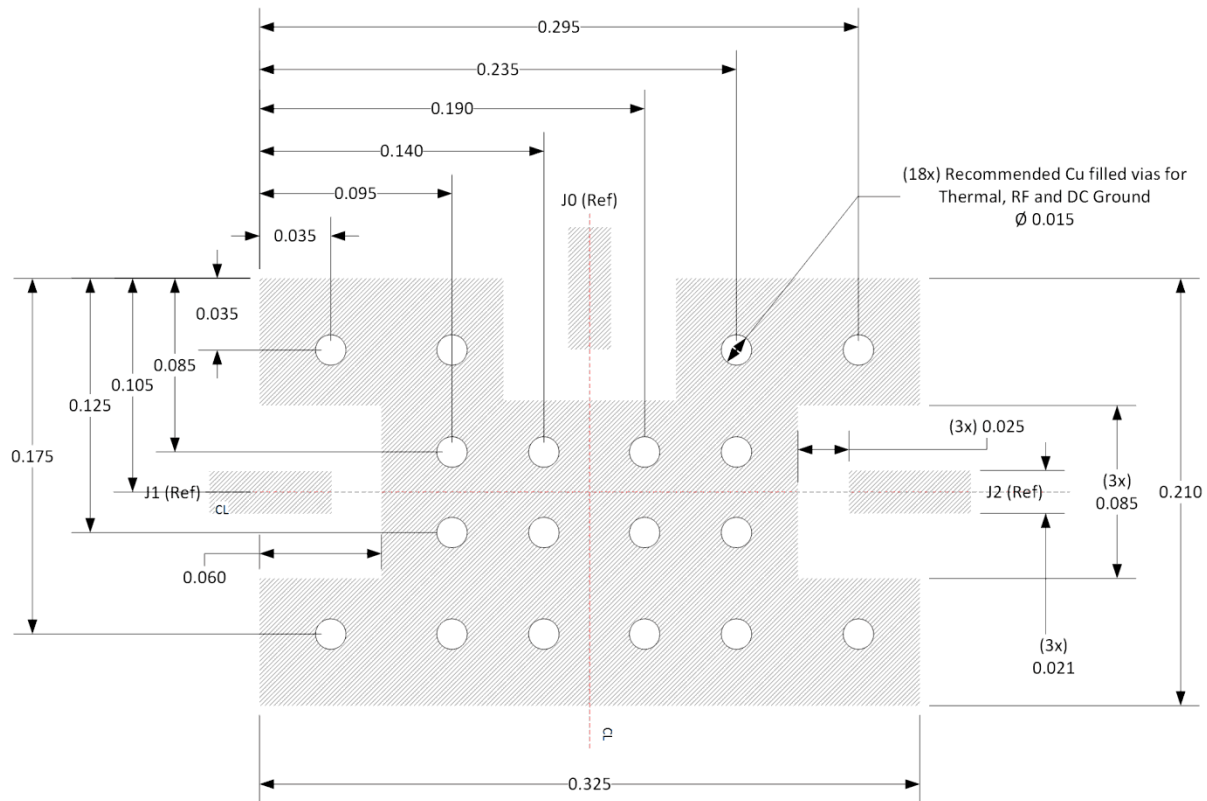

Note: All dimensions in inches.

### Part Number Ordering Details

Part Number	Packaging
MSW2T-0025-195	Tube or Tray
MSW2T-0025-195TR	Tape & Reel (250 pcs)